



Using Accessories with VideoRay Pro and Deep Blue

Accessories Overview

VideoRay Pros and Deep Blue ROVs support a wide variety of accessories that make them the perfect submersible platform for just about any underwater mission. These accessories include a mechanical manipulator (or gripper), scanning sonar, positioning systems, ship hull inspection systems, thickness gauges, water quality monitors and other devices. For a current list of available accessories, visit <http://www.videoray.com/>.

Some of these accessories require the use of a separate control and/or interface device, typically a computer, which can be connected to the VideoRay Integrated Control Box (ICB) via the connector labeled RS-232 AUX, or in the case of the positioning system, a specialized connector mounted on the ICB.

In addition, VideoRay PC Pilot, a software application that enables computer control, is available for VideoRay Pros and Deep Blue. A user supplied computer and joystick can be configured to control the ROV. Computer control offers significant options for customizing the interface controls. PC Pilot also allows VideoRays to be controlled over the Internet.

Accessory Connector Overview

VideoRay accessories are connected to the ROV using an accessory port connector located at the rear of the ROV's float block. The accessory itself is usually mounted in special wells on the float block or attached to the skid.

CAUTION *The accessory port connector must always be terminated with a terminated accessory (such as the gripper), or an accessory port terminator plug before the ROV is submersed. Figure 1 shows the Accessory Port Terminator plug, and Figure 2 shows it connected to the Accessory Port.*



Figure 1 – Accessory Port Terminator Plug



Figure 2 – Sealed Accessory Port

Using Multiple Accessories

Most accessory plugs use a pass-through design that includes a male connector on one side and a female connector on the other side so that multiple devices can be connected at the same time. Figure 3 shows the pass-through connector.

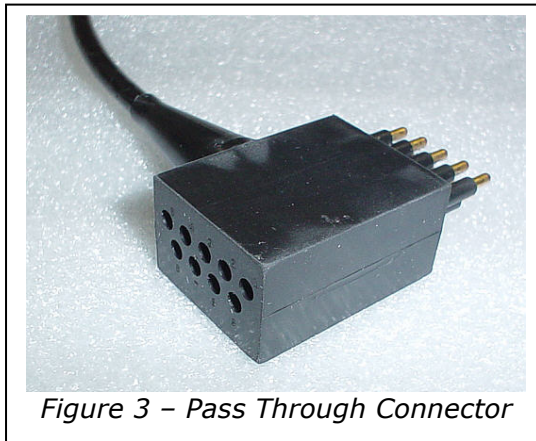

There are limitations to the number and type of accessories that can be connected to a VideoRay at one time.

There is only one spare pair of conductors in the tether, so only one device that requires the use of this spare pair can be connected at a time. Also, a similar limitation exists for the RS-232 AUX connector on the Integrated Control Box (ICB). The RS-232 AUX port actually supports one RS-232 interface and an AUX interface (RS-485), which use different pins. In order to use multiple accessories, or computer control with an accessory that requires the RS-232 AUX connector at the same time, an RS-232 AUX splitter cable may be required. This cable is available from VideoRay.

The following table indicates whether a particular accessory uses either the spare pair or the RS-232 AUX interface.

Accessory Compatibility

Accessory	Uses Spare Pair?	Uses RS-232 AUX?
Manipulator	N	N
Sonar	Y	Y (RS-485)
Positioning Systems		
PILOT	N	N
PILOT w/ GPS	N	N
AquaMap ShipHull	Y	Y (RS-485)
Audio Annotation Microphone*	N	Y
Computer Control	N	Y (RS-232)



The Audio Annotation Microphone requires the use of the RS-232 AUX connection for power only, and includes a pass-thru cable to allow other accessories to use the RS-232 AUX connector.

Accessory Splitter Schematic

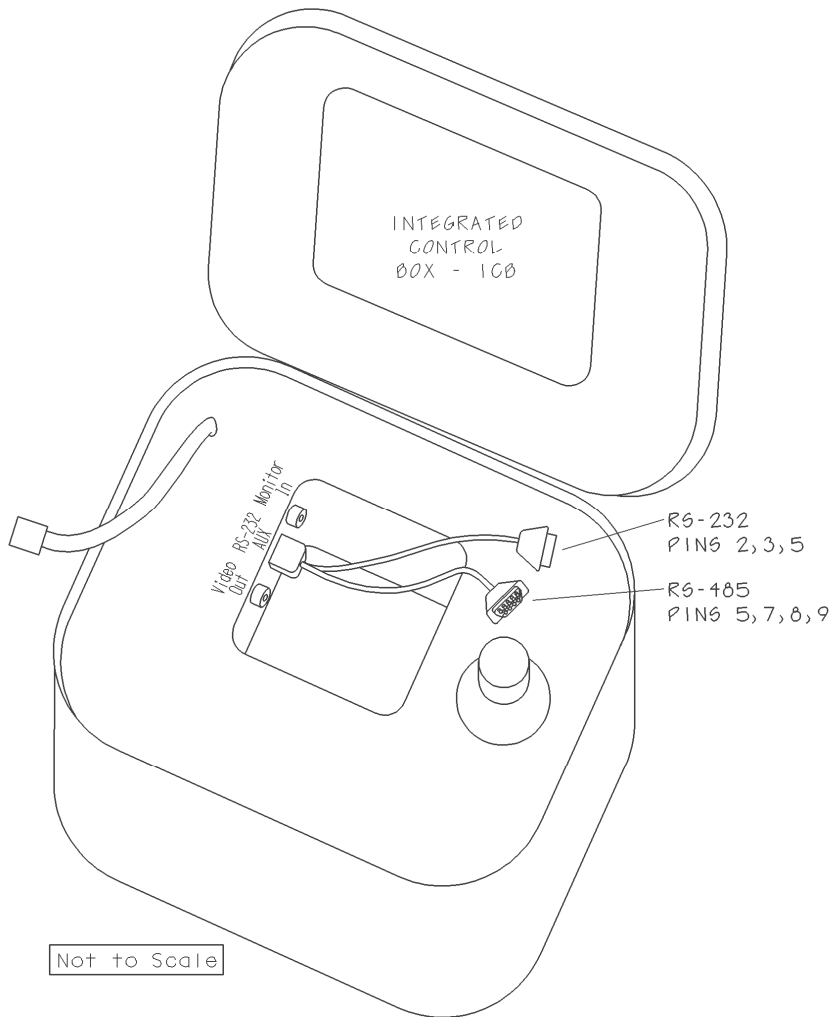
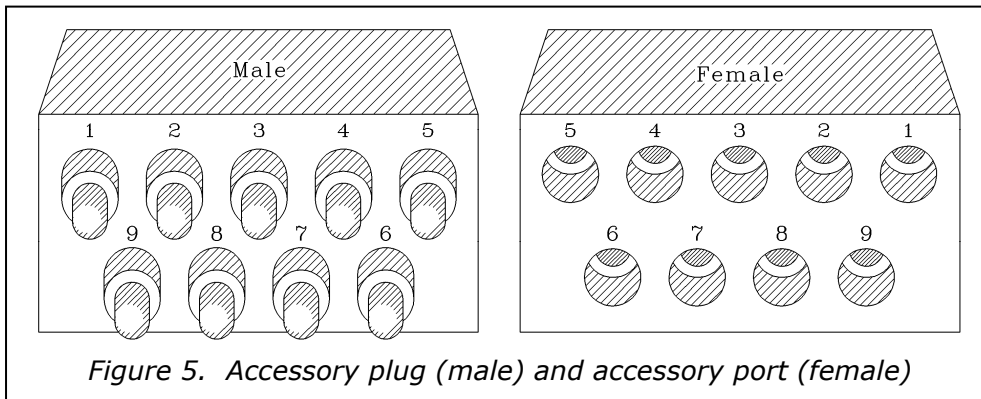

Figure 4 – Accessory Splitter connected to Integrated Control Box

Accessory Splitter Pin Assignments

Pin	Function	Computer Control	Instrument	Color
1	n/a			
2	COM+	X		Red
3	COM-	X		Orange
4	n/a			
5	Ground	X	X	Green
6	n/a			
7	AUX+		X	Purple
8	AUX-		X	Grey
9	+12 Volts		X	Black

Accessory Port Wiring



Pin Assignments by Pin Number

Pin	Function (Pro 3 / Deep Blue)	Function (Pro 4)
1	Video -	Video -
2	Video +	Video +
3	48 VDC +, 30 Watts*	24 VDC +, 30 Watts
4	Aux +	Aux +
5	Ground	Power Common (Ground)
6	Aux -	Aux -
7	Manipulator 24 VDC -	RS-485 Tx
8	Manipulator 24 VDC +	RS-485 Rx
9	12 VDC +, 6 Watts	12 VDC +, 30 Watts

Pin Assignments by Pin Function

Pin	Function (Pro 3 / Deep Blue)	Function (Pro 4)
9	12 VDC +, 6 Watts	12 VDC +, 30 Watts
3	48 VDC +, 30 Watts*	48 VDC +, 30 Watts
6	Aux -	Aux -
4	Aux +	Aux +
5	Ground	Power Common (Ground)
8	Manipulator 24 VDC +	RS-485 Rx
7	Manipulator 24 VDC -	RS-485 Tx
1	Video -	Video -
2	Video +	Video +

* - Pro 3 power regulation allows this voltage to vary as lights and thrusters are engaged. Voltage drop depends on tether length and load.